

## ECOPOWER® High-Efficiency Toilet Flush Valve for Reclaimed Water, 1.28 GPF

### FEATURES

- 1.28 GPF
- Designed with robust materials necessary for reclaimed water use
- Self-powered hydroelectric flush valve system
- No minimum daily usage requirement
- Durable chrome plated body with tamperproof screws and solid bronze valve body
- Self-cleaning piston valve with 360° filter screen
- Neutral rough-in and adjustable tail piece connection
- True mechanical flush override
- Smart sensor with self-adjusting detection range
- 6 second detection time to prevent ghost flushing
- For toilet with 1-1/2" top spud inlet
- Exposed flush valve with 1" angle stop and 1-1/2" vacuum breaker set
- Contributes to LEED® aggregate water consumption reduction
- Protects trap seal with a maintenance flush if not used in a 24 hr period
- IoT-enabled options available to remotely monitor usage rates, water consumption, fixture performance and streamline operations in real time with instant alerts

### OPTIONAL ACCESSORIES

- **Z-4000-J**  
Adapter for ground joint angle stops

### COLORS/FINISHES

- #CP Polished Chrome

### MODELS

Kit Options	Component Breakdown		
	Flush Valve	Vacuum Breaker Set	IoT Card
<b>TET1LBXi32#CP</b>	TET1LBXi#CP	VB0932XB#CP	*
<b>TET1LBXi4#CP</b>	TET1LBXi#CP		THP3566
<b>TET1LBXi432#CP</b>	TET1LBXi#CP	VB0932XB#CP	THP3566

\*Requires communication card (sold separately) for IoT functionality



### PRODUCT SPECIFICATION

TOTO® Model No. \_\_\_\_\_ Product shall be 1.28 GPF. Product shall be an automatic infrared sensor-activated, toilet flush valve. Product shall use hydropower, ECOPOWER flush valve system. Product shall have durable chrome plated body with tamper-proof screws and solid bronze valve body. Product shall have smart sensor with self-adjusting detection range. Product shall have neutral rough-in and adjustable tail piece connection. Product shall have true mechanical flush override. Product shall have 6 second detection time to prevent ghost flushing. Product shall have piston with debris screen and solenoid with self-cleaning mechanism.

### CODES/STANDARDS

- Meets or exceeds ASSE 1037/ASME A112.1037/CSA B125.37
- FCC compliant to Part 15
- Certifications: IAPMO(cUPC), EPA WaterSense, State of Massachusetts, and others
- Code Compliance: UPC, IPC, NSPC, NPC Canada, and others
- ADA compliant
- Complies with CA Prop 65 warning requirements
- Complies with CA Title 20 regulations and CalGreen when paired with a water closet which has an equivalent water consumption.



# TET1LBXi Series

## ECOPOWER® High-Efficiency Toilet Flush Valve for Reclaimed Water, 1.28 GPF

### SPECIFICATIONS

<b>Material</b>	Bronze casting
<b>Power Supply</b>	ECOPOWER
<b>IoT Capacity</b>	IoT-Enabled
<b>Sensor Detection Time</b>	Factory setting at six (6) seconds minimum
<b>Sensor Detection Range</b>	Self-adjusting to environment
<b>Discharge Quantity</b>	Preset to 1.28 GPF / 4.8 LPF
<b>Operating Temperature</b>	32-104°F (0-40°C)
<b>Water Source</b>	See Reclaimed Water Chart
<b>Water Supply Pressure</b>	Min: 25 psi (flowing) Max: 125 psi (static)
<b>Water Supply Connection</b>	1" NPT
<b>Warranty</b>	Three year limited

\*Water pressures over 80 psi are not recommended for most plumbing fixtures. Check your local plumbing code for details.

### INSTALLATION NOTES

RECLAIMED WATER QUALITY PARAMETERS	
<b>Chloride Ion Concentration</b>	< 600mg/L
<b>pH</b>	5.8-8.6
<b>Free Carbonate</b>	< 50mg/L
<b>Langelier's Index</b>	> -3.00
<b>Nitrate Ion Concentration</b>	< 60mg/L
<b>Conductivity</b>	< 250mS/m
<b>Sulfate Ion Concentration</b>	< 100mg/L
<b>Residual Chloride Concentration</b>	< 2mg/L
<b>Hydrogen Sulfide Gas</b>	None Existence
<b>Suspended Solids</b>	< 5mg/L

- TOTO® Reclaimed Water flush valves are designed to perform best when used with TOTO Reclaimed Water urinals/toilets and components. Although TOTO Reclaimed Water products may be used in combination with other reclaimed water product brands, optimal performance might be impaired and attempted use with any non-compliant reclaimed water product(s) could result in corrosion, leakage or void the warranty.
- For commercial applications only. Product designed for reclaimed water use (with parameters specified above).
- Warning: Adjust control stop for proper flow rate to the fixture. Failure to properly adjust angle stop to the appropriate level can potentially cause property damage.
- For detailed installation instructions, please refer to the installation manual. Confirm with local codes and standards for floor drain requirement.
- Max flow rate to be used with TET1LBXi \_\_\_\_\_: 1.28 GPF
- Confirm with local codes and standards for floor drain requirement. Adjust control stop for proper flow rate to the fixture.
- For IoT installation, provide at least 13/16" (20mm) clearance between the back of the flush valve and the wall. Please refer to the diagram below

### DIMENSIONS

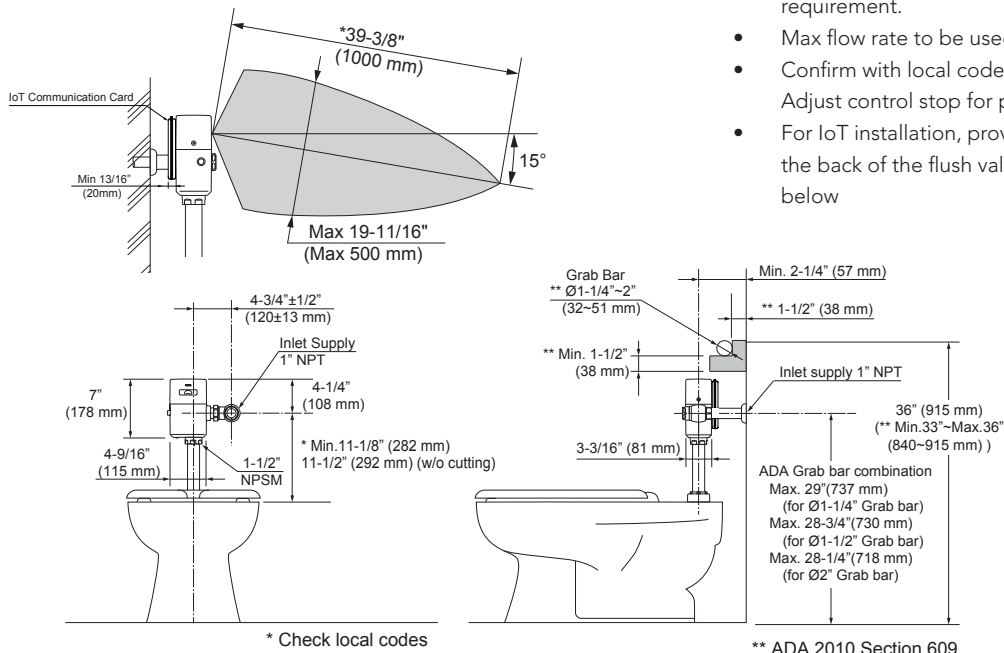

**TOTO®**

These dimensions and specifications are subject to change without notice