

TR56D1

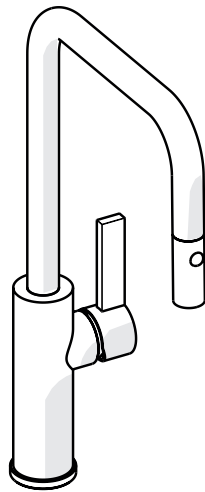

TR66D1

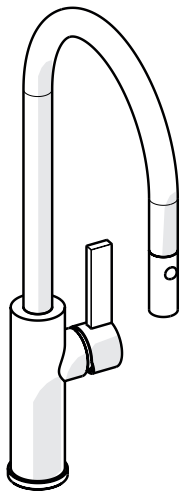

TR55D1

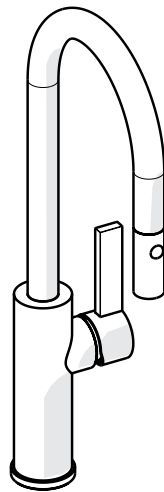

TR65D1

## INSTRUCTION MANUAL MANUEL D'INSTRUCTIONS MANUAL DE INSTRUCCIONES

Tuario™ Pulldown Faucet - U Spout - C Spout  
Tuario™ Pulldown Bar/Food Prep Faucet - U Spout - C Spout

Tuario™ robinet de cuisine avec douchette 2 jets  
Tuario™ robinet monotrou pour évier de bar avec douchette 2 jets

Tuario™ Monocomando fregadero de ducha caño giratorio  
Tuario™ Monocomando bar de ducha caño giratorio

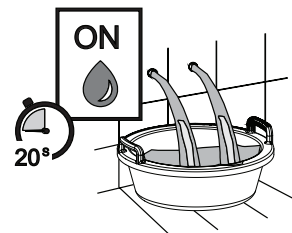

For warranty or additional information, contact:  
Pour la garantie ou des informations supplémentaires, contactez:  
Para garantía o información adicional, comuníquese con:

U.S.A.  
houseofrohl.com/support  
1-800-777-9762

QUEBEC / MARITIMES / WESTERN CANADA  
QUÉBEC / MARITIMES / OUEST CANADIEN  
QUEBEC / MARITIMOS / CANADA OCCIDENTAL  
houseofrohl.ca/support  
1-866-473-8442

ONTARIO  
houseofrohl.ca/support  
1-800-287-5354

Riobel

PERRIN & ROWE  
LONDON



victoria ⊕ albert®

ROHL

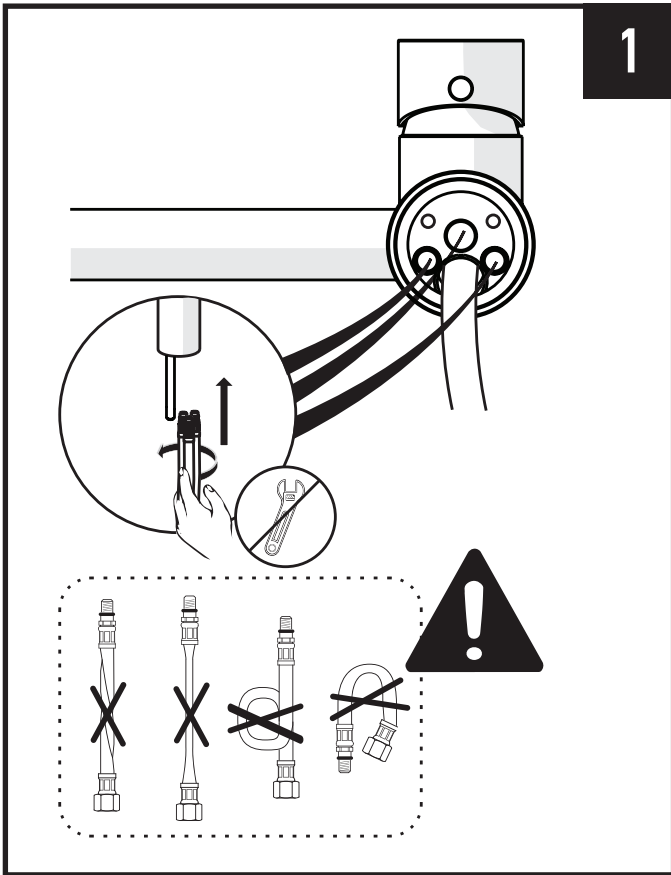

1

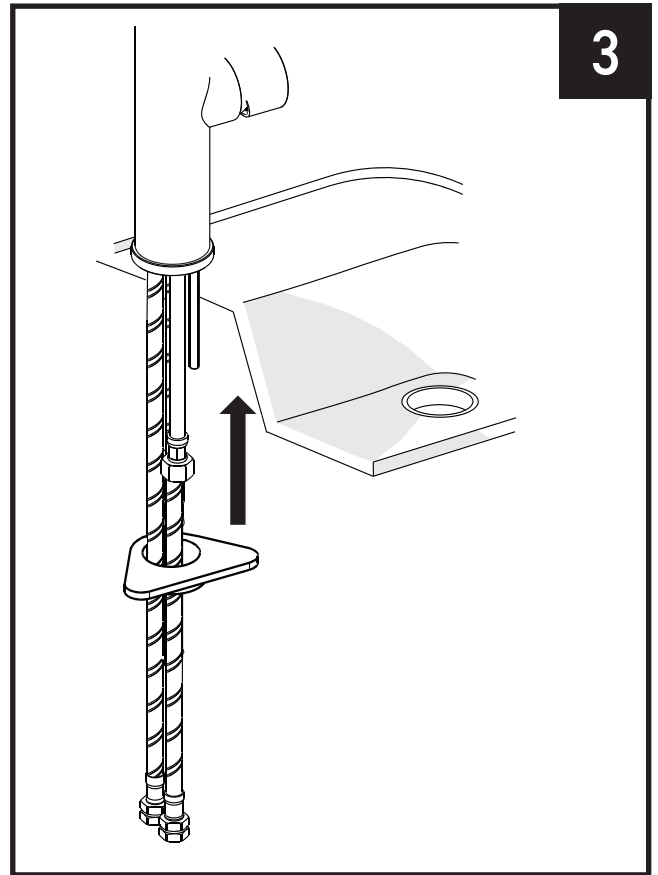

3

Hand tighten the supply lines. Do not tighten with a wrench.

Avoid sharp bends in the supply lines or unusual twisting.

Serrez à la main les conduites d'alimentation. Ne serrez pas avec une clé.

Évitez les virages serrés dans les lignes d'alimentation ou les torsions inhabituelles.

Apriete a mano las líneas de suministro. No apriete con una llave inglesa.

Evite curvas cerradas en las líneas de suministro o giros inusuales.

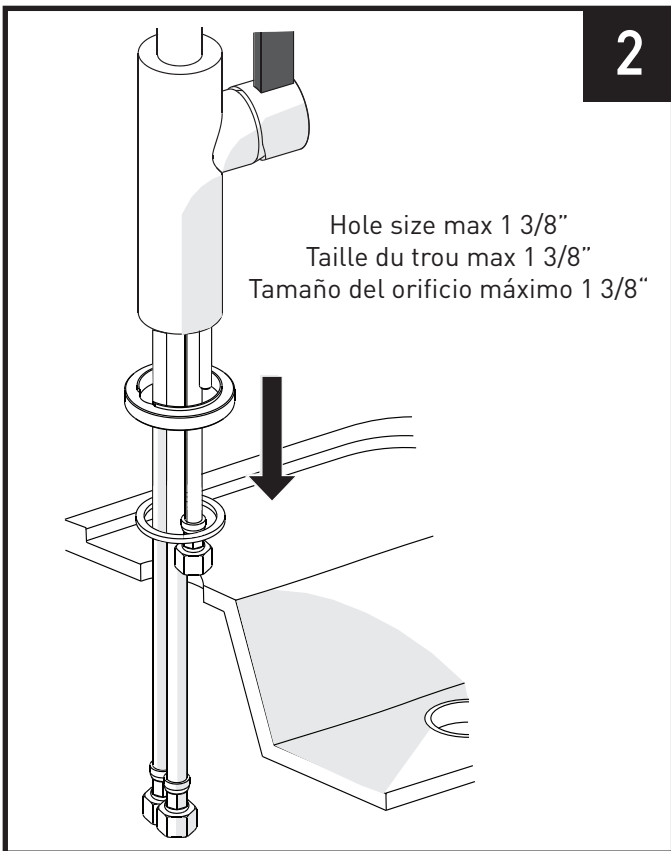

2

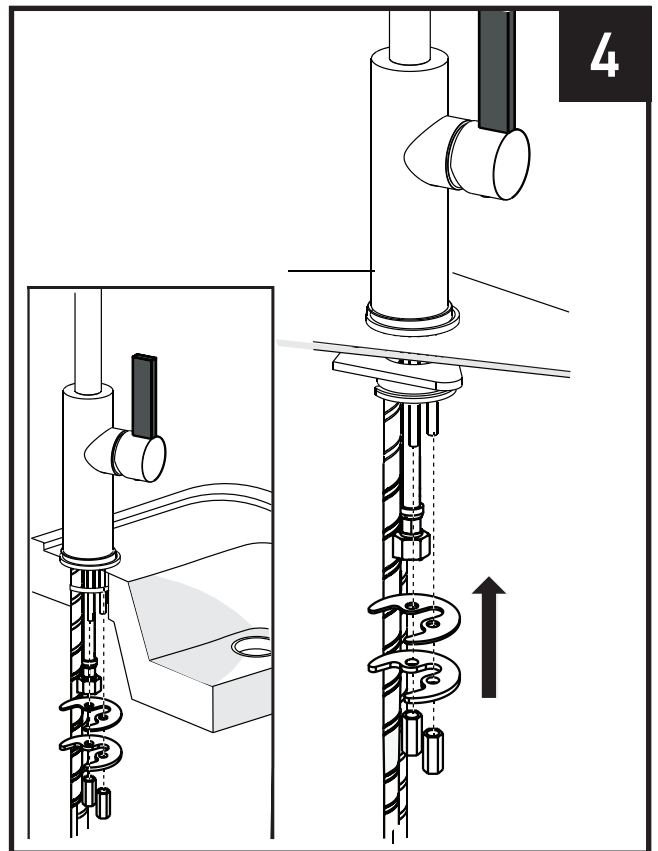

4

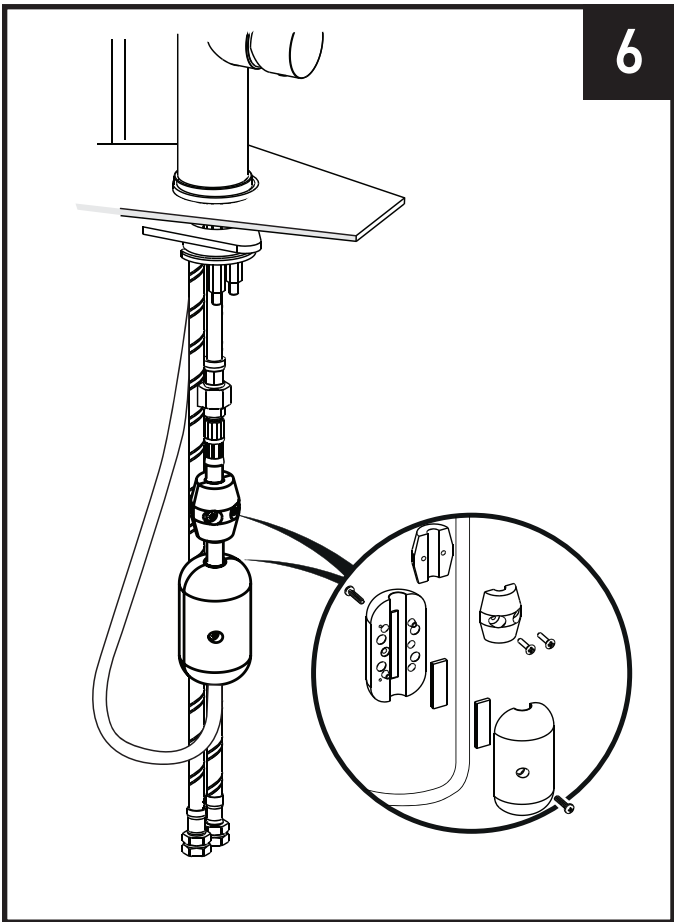
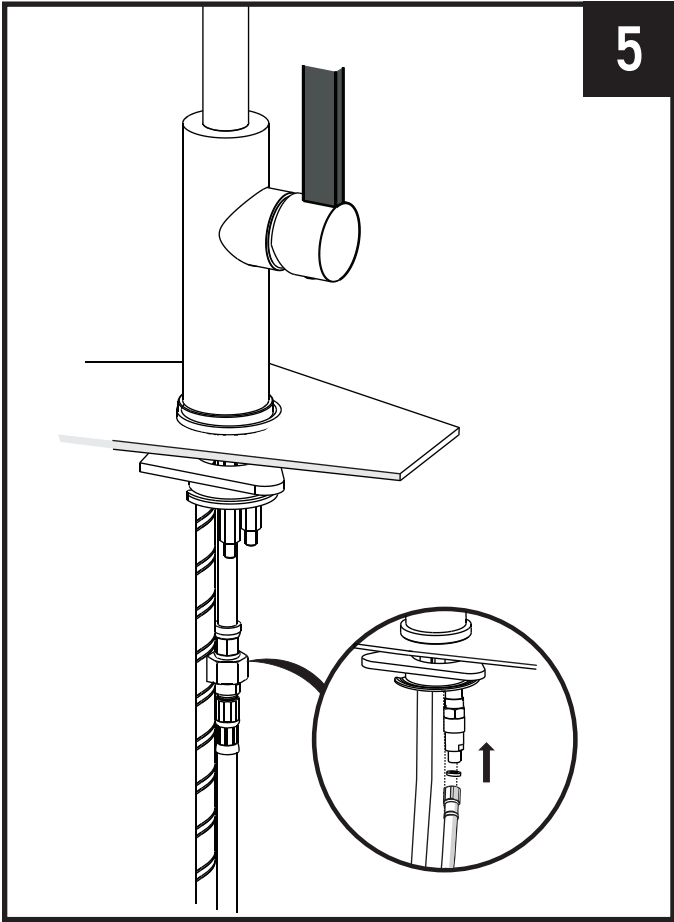

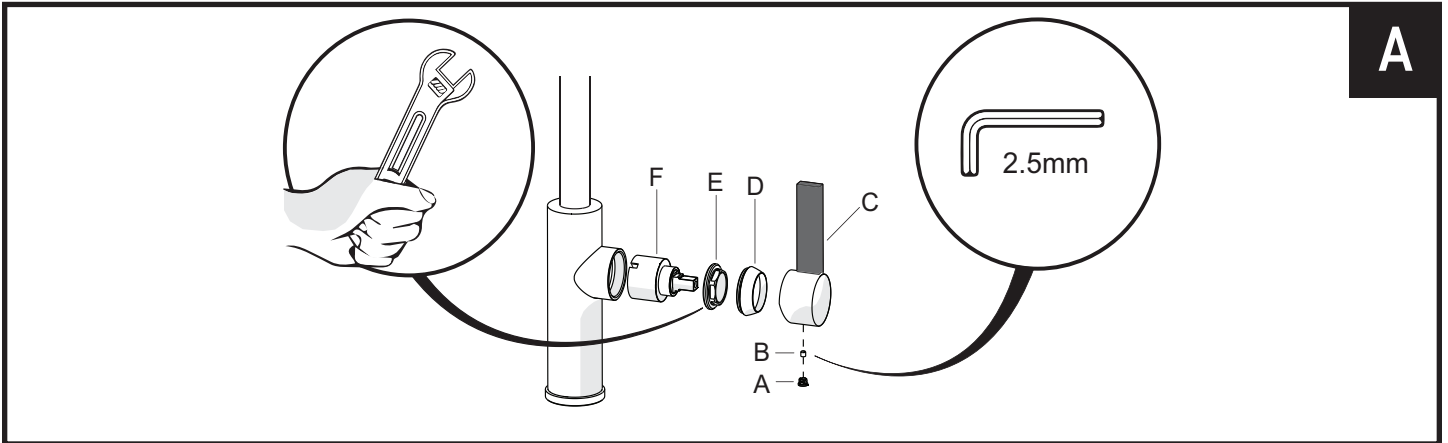
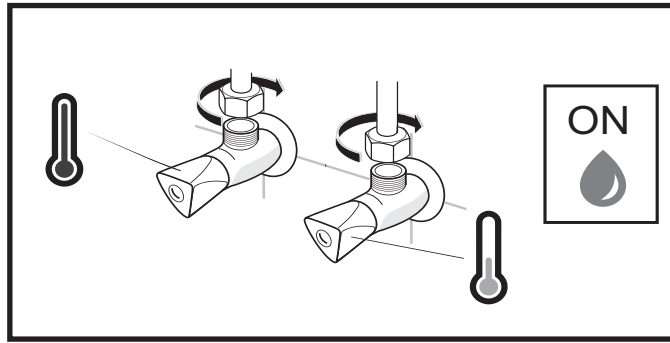

Tools needed for servicing the cartridge. Do not overtighten the nut. Hand tighten the nut and then tighten 1/8 to 1/4 turn. Test for leaks before installing the lever.

Outils nécessaires pour l'entretien de la cartouche. Ne serrez pas trop l'écrou. Serrer l'écrou à la main puis serrer de 1/8 à 1/4 de tour. Testez les fuites avant d'installer le levier.

Herramientas necesarias para reparar el cartucho. No apriete demasiado la tuerca. Apriete a mano la tuerca y luego apriete 1/8 a 1/4 de vuelta. Pruebe si hay fugas antes de instalar la palanca.

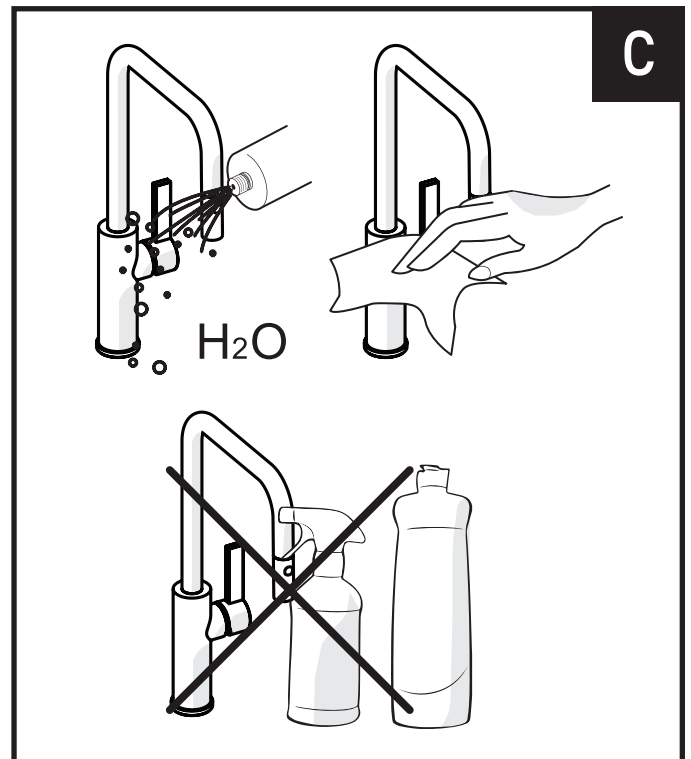
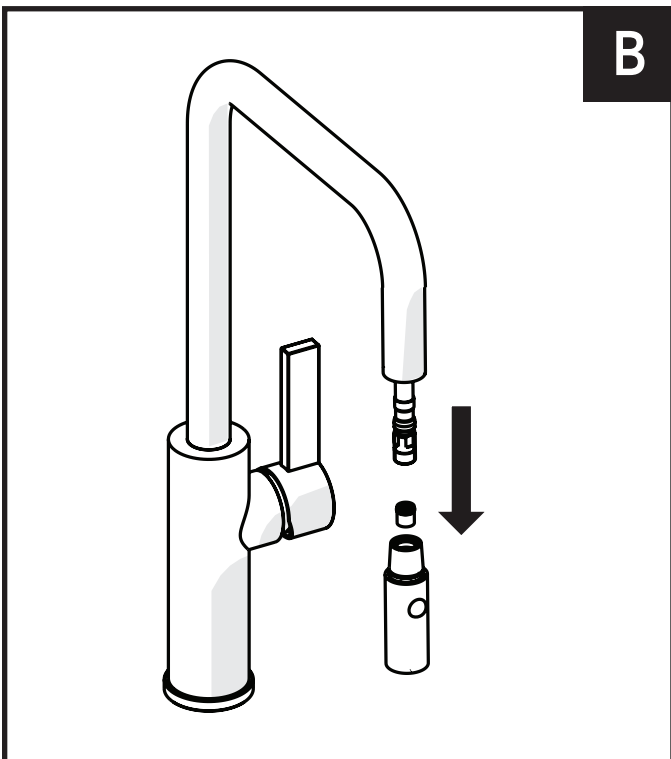

Do not clean with abrasive, alcohol, bleaches or ammonia.

Ne pas nettoyer avec un abrasif, de l'alcool, de l'eau de Javel ou de l'ammoniaque.

No limpiar con abrasivos, alcohol, lejía o amoníaco.