

Standard-R Touchless Faucet

FEATURES

- The choice of self-generating hydropowered ECOPOWER® system or AC system
- IoT-ready product (ECOPOWER models only) – requires communication card sold separately for IoT functionality
- Micro-sensor positioned underneath the spout head provides accurate hand detection and ensures smooth, consistent water distribution
- Vandal resistant nozzle
- Laminar flow
- Durable chrome plated spout body
- Kit includes spout body, controller box, and mounting hardware (supply lines not included)
- Equipped with 1.0 gpm flow control. 0.18 gpc, 10 sec on-demand flow
- IoT-enabled options available to remotely monitor usage rates, water consumption, fixture performance and streamline operations in real time with instant alerts



CODES/STANDARDS

- Operates below federally mandated consumption limit of 0.25 gpc
- Complies to California Green Building Code, CALGreen max flow of 0.20 gpc
- Meets or exceeds ASME A112.18.1/CSA B125.1, and NSF 372
- Meets or exceeds UL 1951, CSA C22.2 No.14 and 68 (AC systems only)
- Certifications: IAPMO(cUPC), California Energy Commission (CEC), State of Massachusetts, and others
- Complies with City of Los Angeles Water Efficiency Ordinance
- ADA compliant
- Complies with Federal and State statutes as low-lead (contains a weighted average of 0.25% lead or less)
- Complies with CA Prop 65 warning requirements
- FCC compliant to Part 15 (for IoT only)

OPTIONAL ACCESSORIES

- **THP3158#CP** - 4" Cover Plate
- **THP3159#CP** - 8" Cover Plate
- **THP3237** - Swivel Coupling

COLORS/FINISHES

- #CP Polished Chrome

PRODUCT SPECIFICATION

TOTO Model # _____ Choice of self-generating hydro-powered ECOPOWER system or AC system. The faucet shall have maximum of 10 seconds on-demand flow (0.18 gpc). The faucet shall have self-adjusting sensor. Product equipped with 1.0 gpm flow regulator.

*For codes and standards of mixing valves TLM10 and TLE05701U, please refer to corresponding product spec sheet

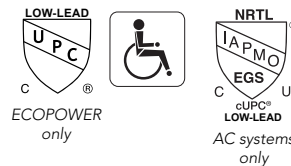

ECOPOWER MODELS

| Kit Options | Component Breakdown | | | | |
|-----------------------|---------------------|---------------------|--------------|---------------------|----------|
| | Spout | ECOPOWER Controller | Mixing valve | Thermo Mixing Valve | IoT Card |
| T28S11Ei#\$\$ | TLE28003U1#\$\$ | TLE03503U1i | | | * |
| T28S11EiM#\$\$ | TLE28003U1#\$\$ | TLE03503U1i | TLM10 | | * |
| T28S11EiT#\$\$ | TLE28003U1#\$\$ | TLE03503U1i | | TLE05701U | * |
| T28S11Ei4#\$\$ | TLE28003U1#\$\$ | TLE03503U1i | | | THP3566 |

*Requires communication card (sold separately) for IoT functionality

AC MODELS (Not IoT Compatible)

| Kit Options | Component Breakdown | | | |
|----------------------|---------------------|---------------|--------------|---------------------|
| | Spout | AC Controller | Mixing valve | Thermo Mixing Valve |
| T28S11A#\$\$ | TLE28003U1#\$\$ | TLE01503U | | |
| T28S11AM#\$\$ | TLE28003U1#\$\$ | TLE01503U | TLM10 | |
| T28S11AT#\$\$ | TLE28003U1#\$\$ | TLE01503U | | TLE05701U |

T28S11i Series

Standard-R Touchless Faucet

SPECIFICATIONS

| Type | ECOPOWER | AC |
|-------------------------|--|---------|
| Power Supply | Hydropower Generation (self-powering power supply) | AC 120V |
| IoT Capability | IoT-Enabled | |
| Sensor Detection Range | 5-1/8" ~ 7-7/8" (130 ~ 200 mm) Sensor is self-adjusting | |
| Water Supply Pressure | Min (Dynamic/Flowing) Pressure: 15 psi (100 kPa) Max (Static) Pressure: 80 psi (551 kPa) | |
| Water Supply | G 1/2" (1/2" NPSM compatible) | |
| Inlet Temperature Range | 39-110°F (4-43°C) | |
| Ambient Temperature | 32-104°F (0-40°C) | |
| Humidity | Max. 90% RH | |
| Flow Rate | 0.18 gpc (0.68 Lpc)** - max 10 second On Demand*** (0.18 gpc = 1.0 gpm x 10/60 sec) Equipped with 1.0 gpm flow control | |
| Warranty | Three years | |

**Gallons per cycle (gpc) is the amount of water discharged per usage cycle.

*** On-demand refers to the way in which the water is dispensed (i.e.; water is only dispensed when the sensor is activated by the user as needed).

DIMENSIONS

Standard-R Touchless Faucet

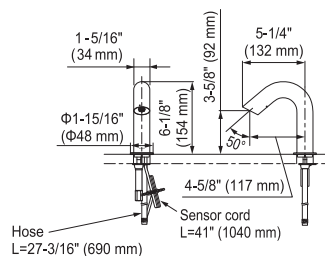

- Mounting deck thickness: 1/4" (5 mm) - 2" (50 mm)
- Spout hole: Ø1-1/4" (Ø32 mm) - Ø1-3/8" (Ø35 mm)

ECOPOWER Controller

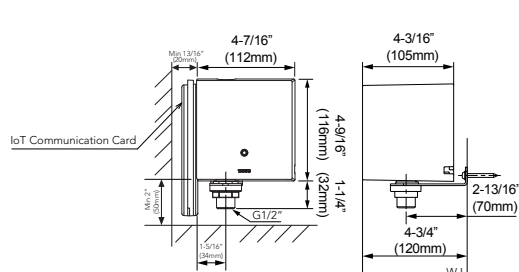

Available Mixing Valves

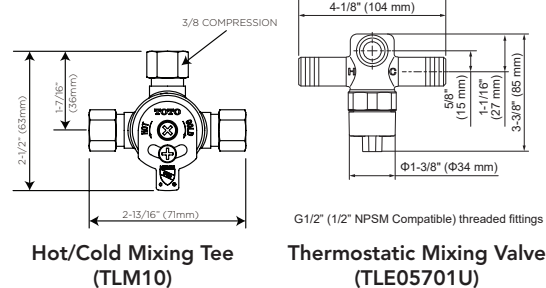

AC Controller

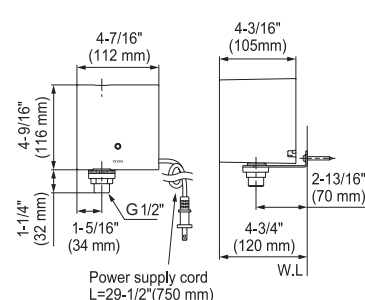

TOTO

NOTES

Following the federal mandate for water efficiency outlined in the Environmental Protection Act of 1992, faucets can be rated for water consumption based on two categories: Flow Rate and Water Consumption. TOTO uses the water consumption standard because it is the most accurate method of measuring water use. TOTO faucets also comply with the CALGreen Guideline of water usage

Water Savings

- TOTO On-Demand [10 sec.] faucet (0.18 gpc):
- 28% savings over Federal Standard (0.25 gpc)
- 10% savings over CAL Green (0.20 gpc)

INSTALLATION NOTES

For IoT installation, provide clearance space on left side and bottom of the controller. For left side: Minimum clearance to any surrounding structure is 13/16" (20mm) . Recommended clearance is 3-15/16" (100mm) or more. For bottom side: Minimum clearance is 2" (50mm). Please refer to the diagram below.